

The following – with example test results – uses of the logos of Stiftung Warentest for the purpose of advertising with test results are permitted:

**For products that have been published in the magazine 'test':**

1. Portrait



**GUT (2,0)**

Ausgabe  
11/2011

www.test.de  
13AB11

2. Landscape narrow



**GUT (2,2)**

Ermittelt am  
Produkt mit  
MHD: 14.03.2011  
Ausgabe 7/2011  
www.test.de

13AB11

3. Landscape wide



Sicherheit: **gut (2,0)**  
Schadstoffe: **sehr gut (1,3)**  
Warnhinweise und Kenn-  
zeichnungen: **sehr gut (1,0)**

Ausgabe 7/2011  
www.test.de

13AB11

4. Identical products



**GUT (1,7)**

Produktgleich mit  
Waschmaschine WAS12345

Ausgabe 10/2011  
www.test.de

13AB11

**For products that have been published in the magazine 'Finanztest':**

5. Portrait



**GUT (1,6)**

Ausgabe 8/2011  
www.test.de  
13AB11

6. Landscape narrow



**SEHR GUT (1,5)**

Ausgabe 7/2011  
www.test.de

13AB11

7. Landscape wide



**Kostenloses Girokonto  
ohne Bedingungen**

Ausgabe 9/2011  
www.test.de

13AB11

For products that have been published in the product finder:

8a. Portrait

<b>Stiftung Warentest</b> <b>test.de</b> 
<b>GUT (1,7)</b> Im Produktfinder <b>Digitalkameras</b> Veröffentlicht am 18.3.2011 <b>www.test.de</b> 13AB11

8b. Landscape narrow

<b>Stiftung Warentest</b> <b>test.de</b> 	<b>GUT (2,1)</b> Im Produktfinder <b>Matratzen</b> Veröffentlicht am 22.10.2010 <b>www.test.de</b>	13AB11
--	---	--------

8c. Landscape wide

<b>Stiftung Warentest</b> <b>test.de</b> 	Sensorische Beurteilung: <b>gut (2,0)</b> Mikrobiologische Qualität: <b>ohne Beanstandung</b> Oberirdische Verunreinigungen: <b>keine Hinweise</b> Deklaration: <b>gut (2,2)</b> Im Produktfinder <b>Natürliche Mineralwässer</b> Veröffentlicht am 29.7.2011 <b>www.test.de</b>	13AB11
---	---	--------

8d. Landscape wide

<b>Stiftung Warentest</b> <b>test.de</b> 	<b>Dauerhaft gut</b> Angebot X hat in den letzten 24 Monaten zu den besten 20 Angeboten ohne Befristung gehört. Im Produktfinder <b>Tagesgeldkonten</b> Veröffentlicht am 30.09.2011 <b>www.test.de</b>	13AB11
--	--	--------

For products that have been published as quick tests:

9.

<b>Stiftung Warentest</b> <b>test.de</b> 	<b>Schnelltest: Ökostrom</b> <b>Test-Kommentar:</b> Interessant ist der Grüne Strom von X für alle, die noch keinen Ökostrom beziehen und in einem teuren Tarif ihres Grundversorgers stecken. Dann lohnt sich der Wechsel gleich doppelt: Für die Umwelt und für Ihr Portemonnaie. Auch überzeugte Umweltfreunde können X als Ökostromanbieter wählen, da ihr Geld unter anderem in neue Ökokraftwerke fließt. Veröffentlicht am 7.12.2010 Zum vollständigen Test: <b>www.test.de</b>	13AB11
--	--	--------

Proportions, Font, font colour:

1. Landscape wide and landscape narrow

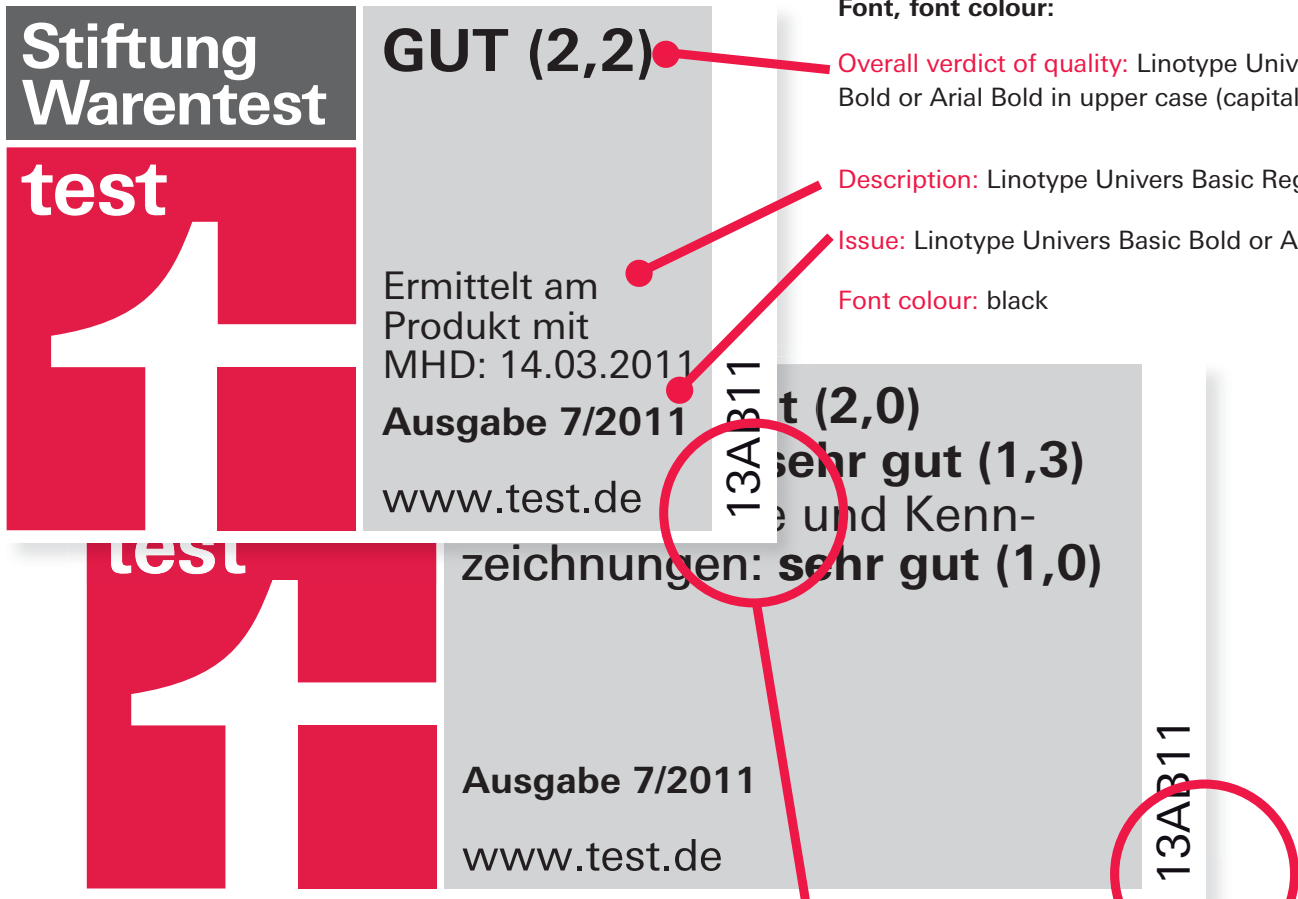

Font, font colour:

**Overall verdict of quality:** Linotype Univers Basic Bold or Arial Bold in upper case (capital letters)

**Description:** Linotype Univers Basic Regular or Arial

**Issue:** Linotype Univers Basic Bold or Arial Bold

**Font colour:** black

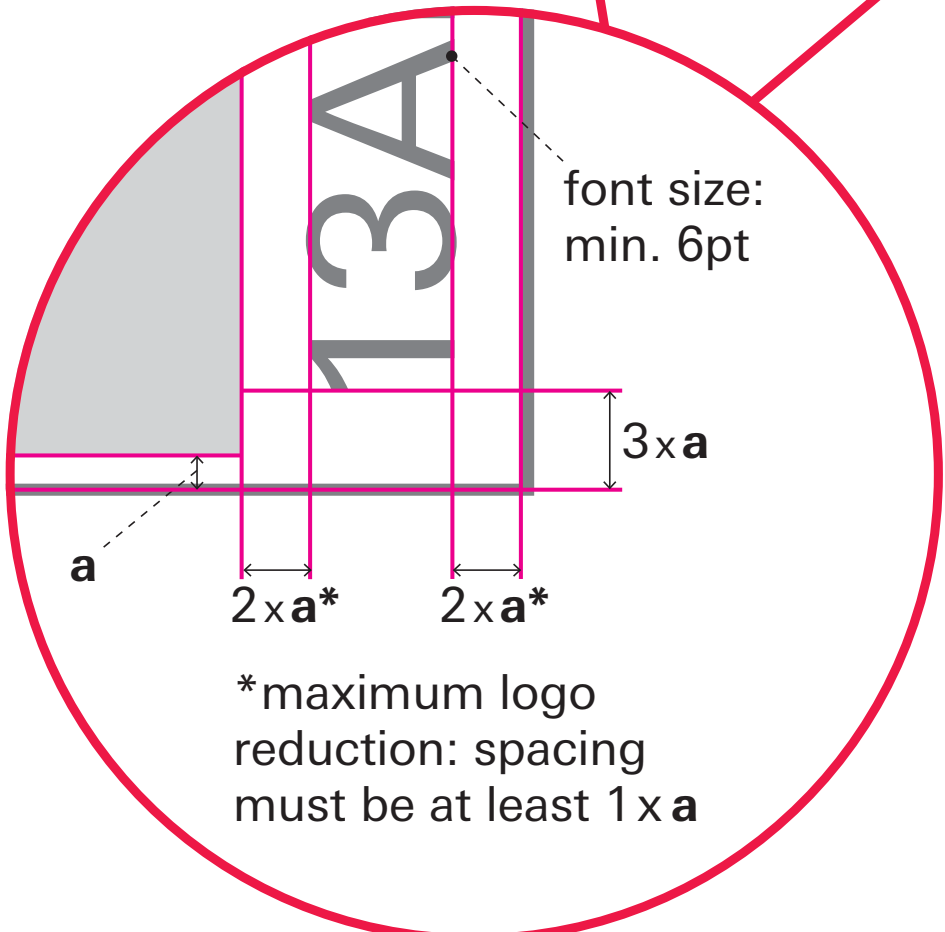

Proportions, Font, font colour:

2. Portrait



Font, font colour:

**Overall verdict of quality:** Linotype Univers Basic Bold or Arial Bold in upper case (capital letters)

**Issue:** Linotype Univers Basic Bold or Arial Bold

**Description:** Linotype Univers Basic Regular or Arial

**Font colour:** black

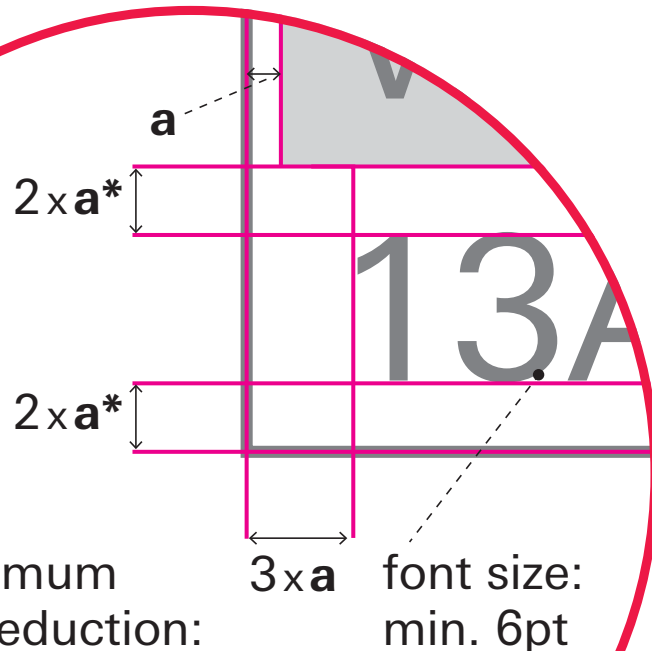

\*maximum logo reduction: spacing must be at least 1 x a

font size: min. 6pt

## Colour stipulations for test logos

	Header	Icon	Grey area for labelling
Special colour uncoated	Pantone Cool Gray 10C	Pantone 199U	27 % Pantone Cool Gray 10C
Special colour coated	Pantone Cool Gray 9C	Pantone 199C	27 % Pantone Cool Gray 9C
4 colour set Black	Cyan = 0% Magenta = 0% Yellow = 0% Black = 75%	Cyan = 5% Magenta = 100% Yellow = 70% Black = 0%	Cyan = 0% Magenta = 0% Yellow = 0% Black = 20%
RGB colour range	R = 102 G = 102 B = 102	R = 219 G = 0 B = 60	R = 218 G = 218 B = 218

## Colour stipulations for Finanztest logos

	Header	Icon	Grey area for labelling
Special colour uncoated	Pantone Cool Gray 10C	Pantone Process Blue U	27 % Pantone Cool Gray 10C
Special colour coated	Pantone Cool Gray 9C	Pantone 3005C	27 % Pantone Cool Gray 9C
4 colour set Black	Cyan = 0% Magenta = 0% Yellow = 0% Black = 75%	Cyan = 100% Magenta = 40% Yellow = 0% Black = 0%	Cyan = 0% Magenta = 0% Yellow = 0% Black = 20%
RGB colour range	R = 102 G = 102 B = 102	R = 0 G = 118 B = 189	R = 218 G = 218 B = 218

## Colour stipulations for test.de logos

	Header	Icon	Grey area for labelling
Special colour uncoated	Pantone Cool Gray 10C	Pantone 144U	27 % Pantone Cool Gray 10C
Special colour coated	Pantone Cool Gray 9C	Pantone 144C	27 % Pantone Cool Gray 9C
4 colour set Black	Cyan = 0% Magenta = 0% Yellow = 0% Black = 75%	Cyan = 0% Magenta = 55% Yellow = 100% Black = 0%	Cyan = 0% Magenta = 0% Yellow = 0% Black = 20%
RGB colour range	R = 102 G = 102 B = 102	R = 255 G = 128 B = 0	R = 218 G = 218 B = 218

Portrait:

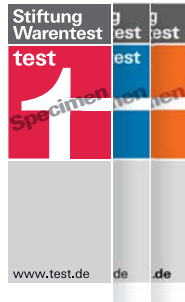

Landscape wide:



Landscape narrow:

